

ACO*fusion*

Aria



**The ceiling
should
disappear.**

**The light should
remain.**

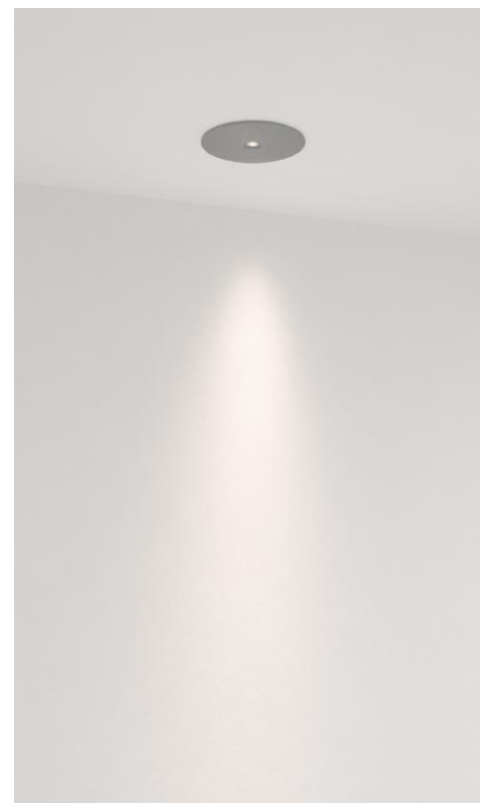

**Controlled
Aperture**





**Sleek and
Compatible**



Warm architectural surfaces.

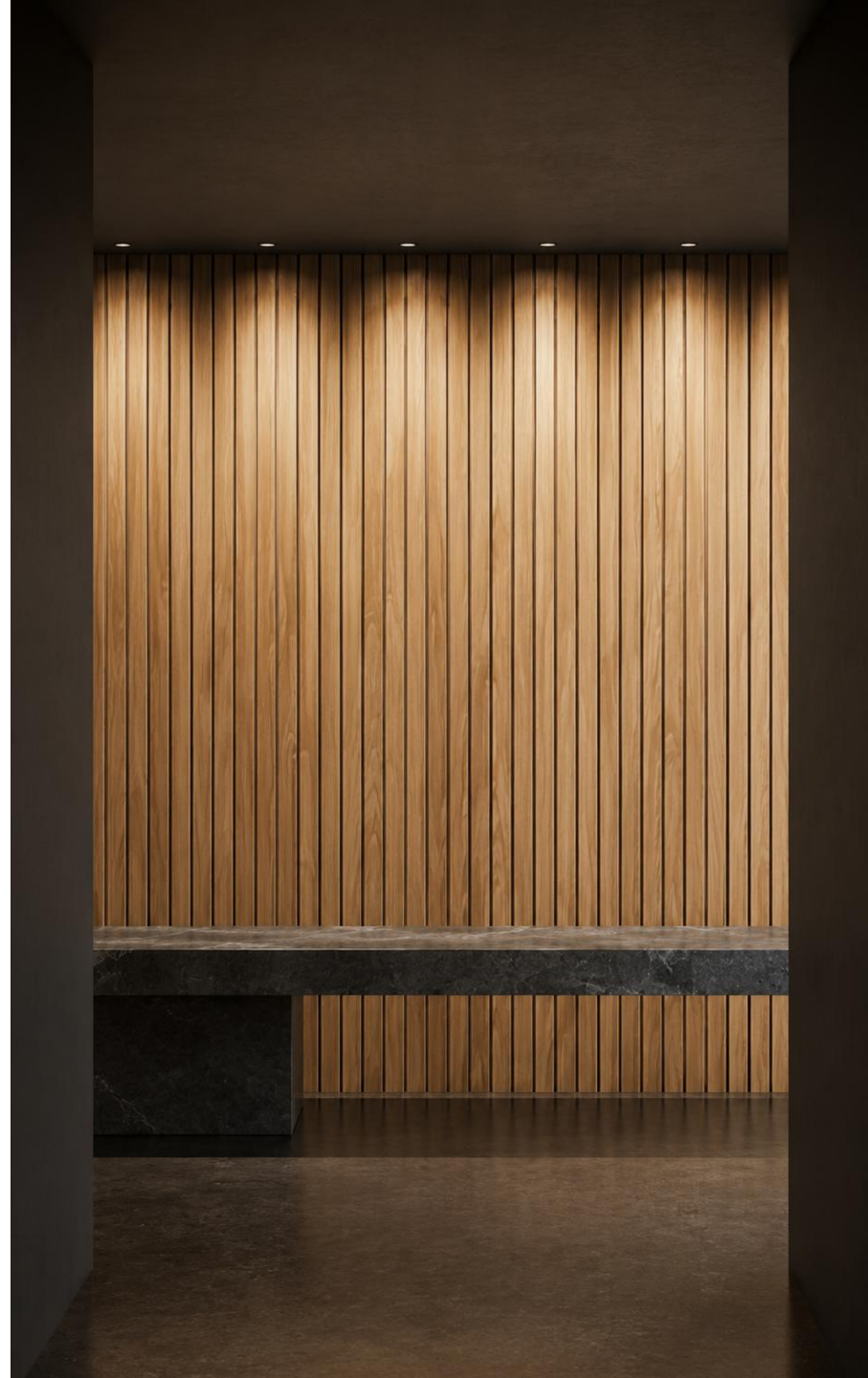
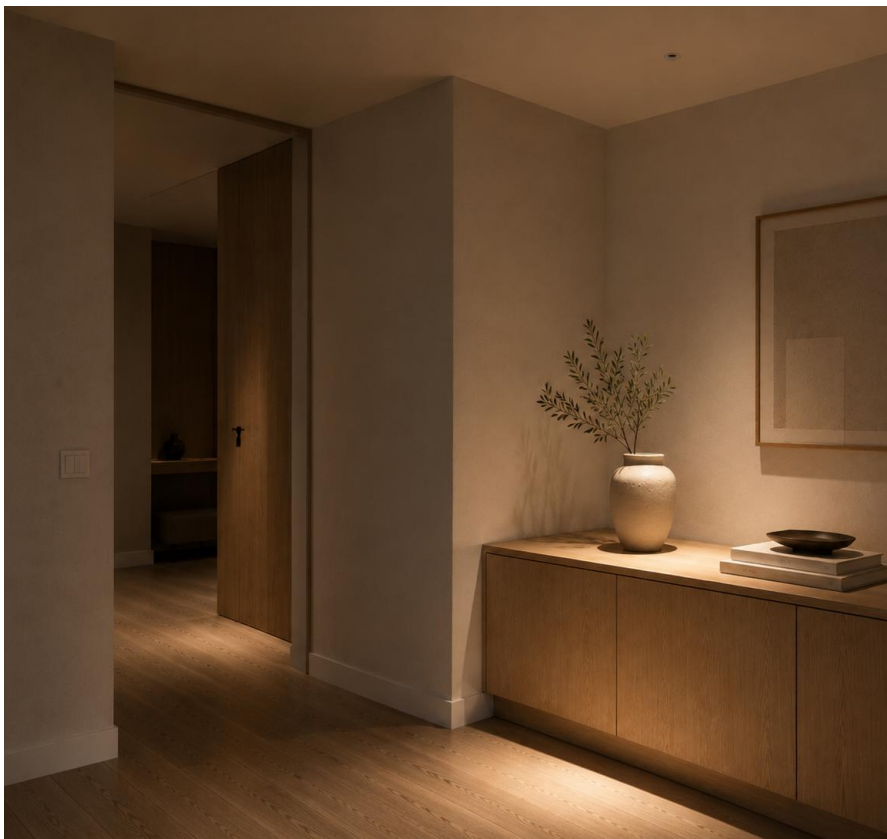

Sleek and Compatible

Use Aria where the vertical surface is the designed element: display walls, timber slats, artwork, circulation routes and retail perimeters.

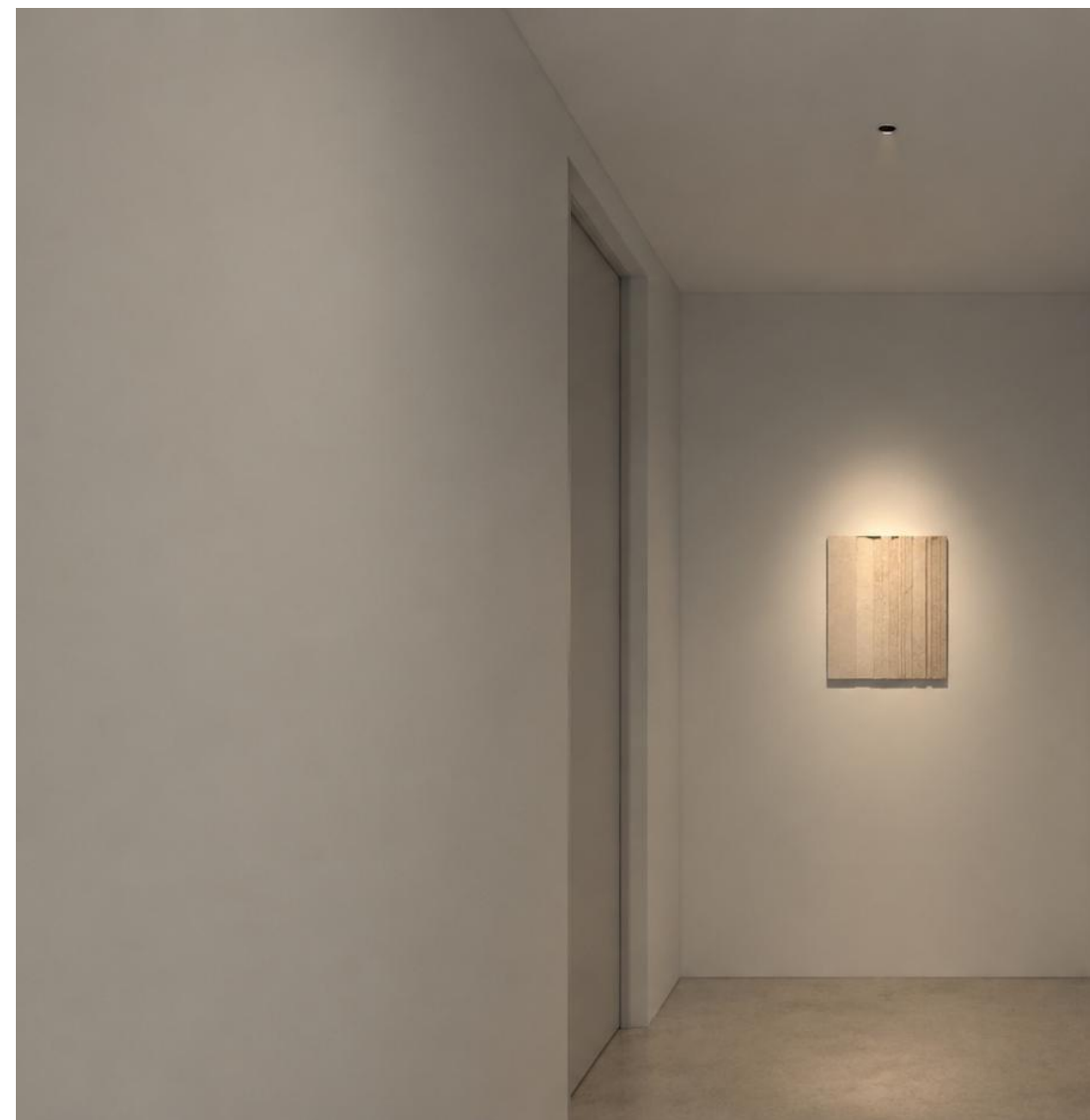
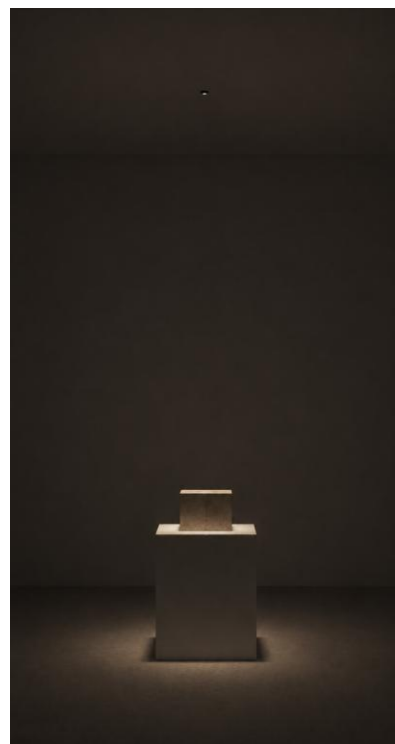
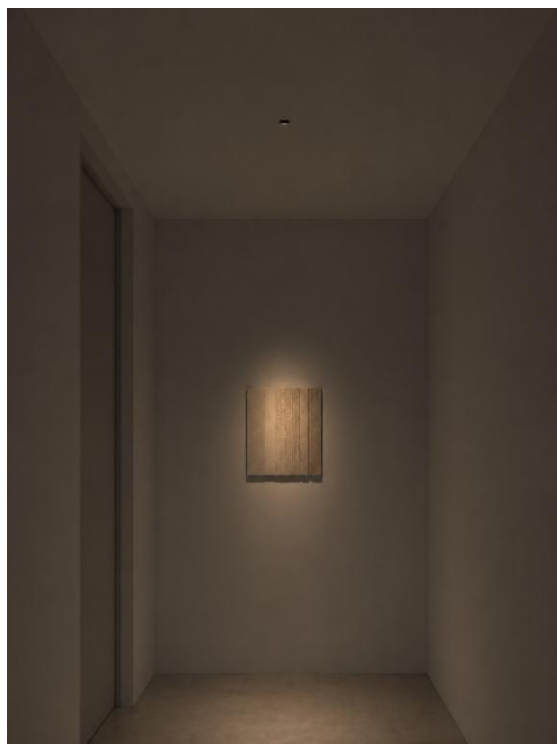

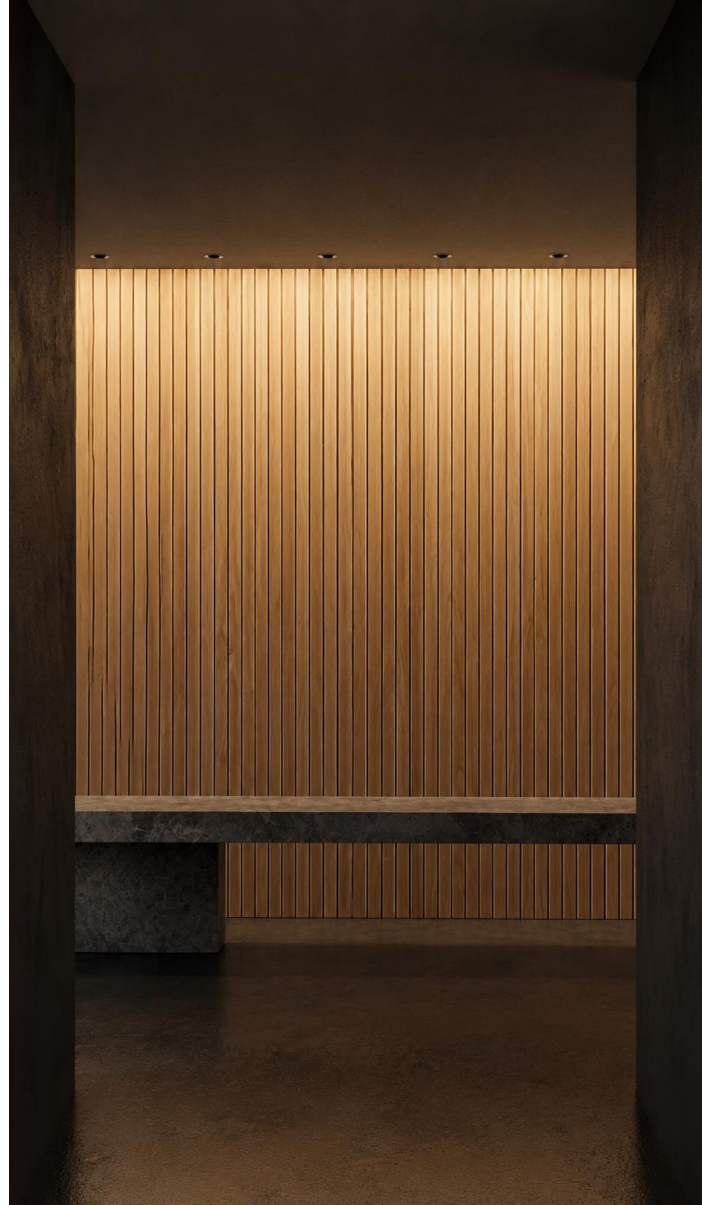
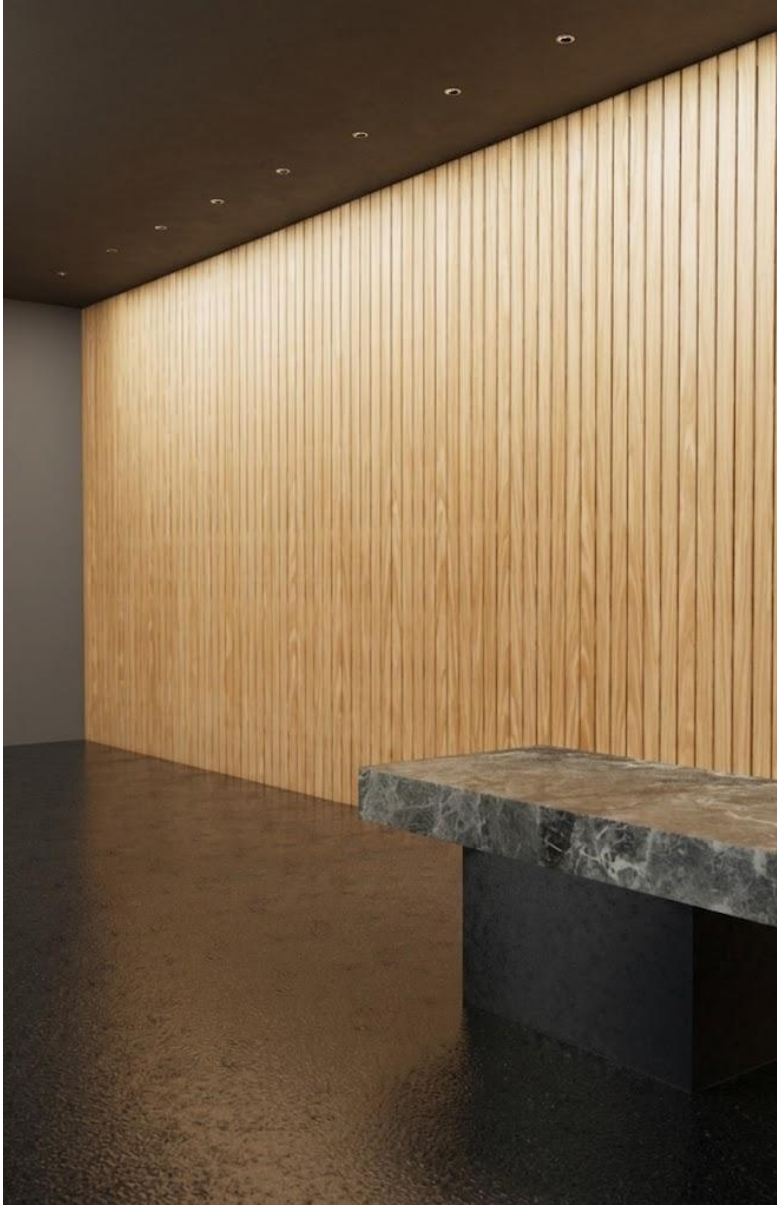

Even light. Clear layout.

Use Aria where the vertical surface is the designed element: display walls, timber slats, artwork, circulation routes and retail perimeters.



Overview

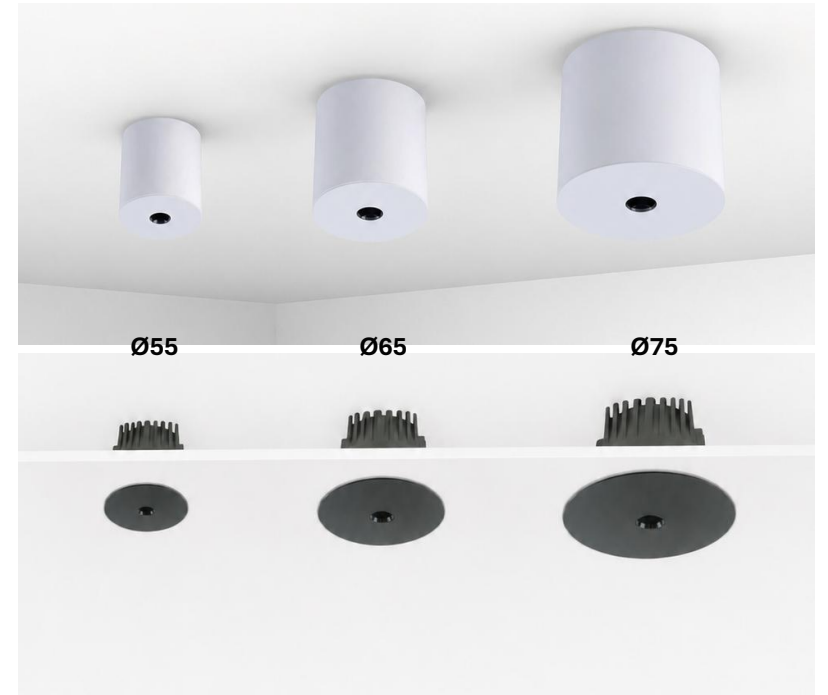

01

Main Recessed Platform

D120-1 / D120-2 / D120-3 / D120-5 / D120-6

- Five aperture sizes
- **8W** to **35W** output range
- **25° tilt** adjustment
- **355° rotation**

02

Configurable Platform

D120-1 / D120-2 / D120-3

- Round / square front options
- Trimmed / trimless installation
- Six front-ring finish options
- Standard / extended 1×2 trimless frames

03

Small-Aperture Route

D120-7 / C50

- Reduced visible aperture
- Compact architectural lighting

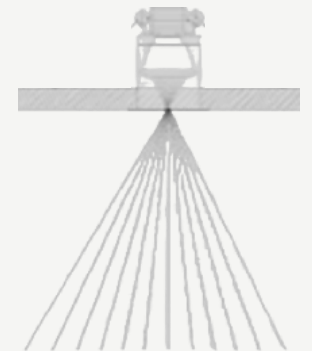

Aria Platform Overview

Wattage

7W



10W



20W



Trim/ Trimless



Front Ring Options



Chrome

Silver

Black Chrome



Rose Gold

White

Black

Asymmetrical Wallwash



Deep Recessed



Bezel Options





Platform Matrix

Lighting that responds. Design that adapts.

From quiet galleries to dynamic retail, Aria brings clarity and control to vertical lighting. Every detail—from optic precision to modular forms—is designed to deliver a uniform wash that adapts to changing needs.

With options for tilt, rotation, and smart control, Aria is more than a fixture—it's a flexible tool for shaping mood, focus, and flow.

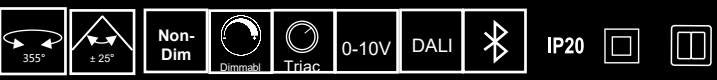

1 LIGHT ENGINE OPTIONS



2 TRIM / OPTIC OPTIONS

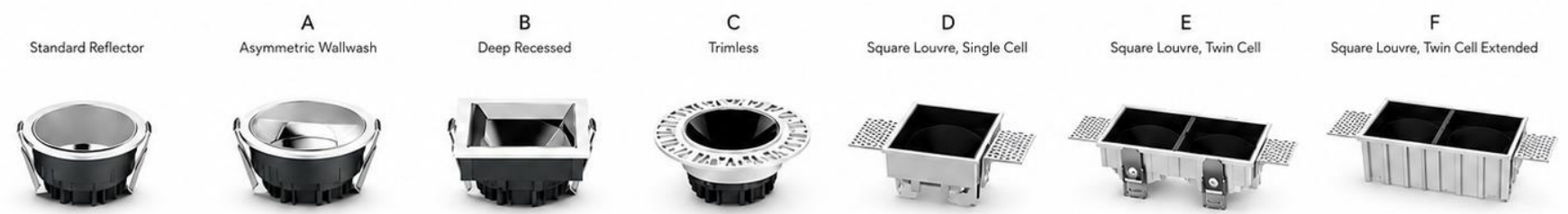

3 COMPLETE CONFIGURATIONS





Main Platform

Lighting that responds. Design that adapts.

From quiet galleries to dynamic retail, Aria brings clarity and control to vertical lighting. Every detail—from optic precision to modular forms—is designed to deliver a uniform wash that adapts to changing needs.

With options for tilt, rotation, and smart control, Aria is more than a fixture—it's a flexible tool for shaping mood, focus, and flow.

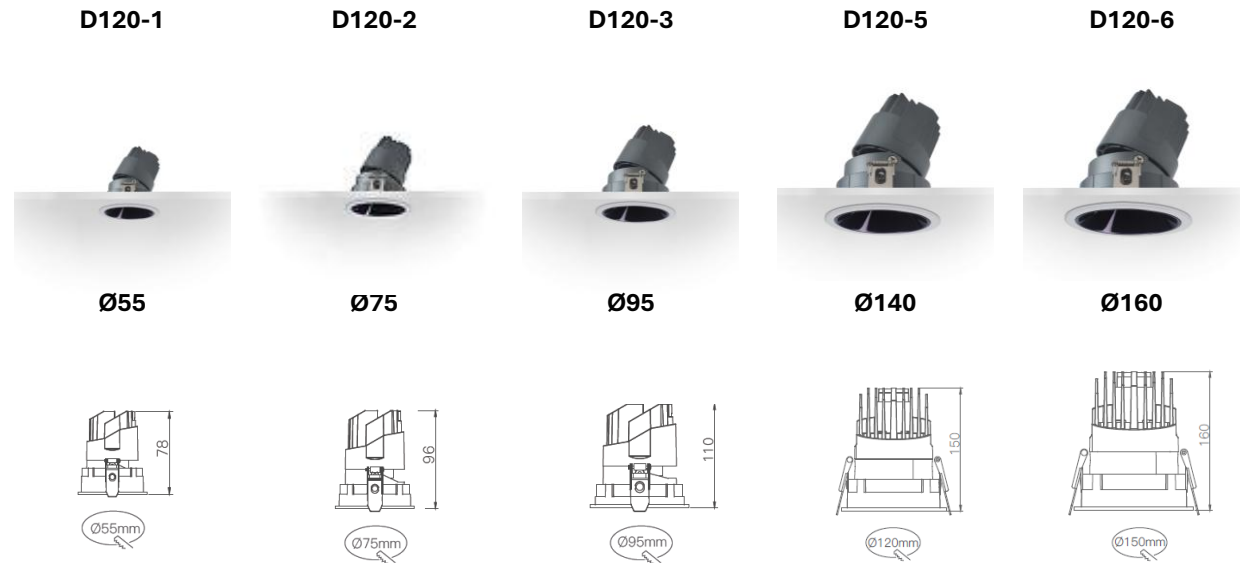

Model	Power	lm	CCT	CRI	SDCM	Beam	Driver	Ctrl
D120-1	7W	470 lm	2700K	90	≤3	20° / 30°	ON/OFF	Bluetooth
D120-2	10W	730 lm	3000K	92	≤3	20° / 30°	0-10V	DALI
D120-3	20W	1350 lm	4000K	95	≤3	20° / 30°	Triac	
D120-5	35W	2500lm	Tunable White	98	≤3	15° / 24° / 36°		
D120-6	35W	3000lm			≤3	15° / 24° / 36°		

Remark	Remark
SDCM≤3	SDCM ≤2 is available by request
CRI-98	On request
	R9 R9 = 60, @CRI90
	R9 = 75, @CRI95
	R15 R15 = 85, @CRI90
	R15 = 90, @CRI95

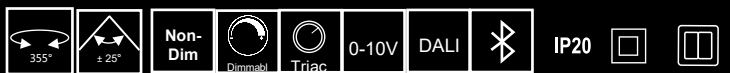

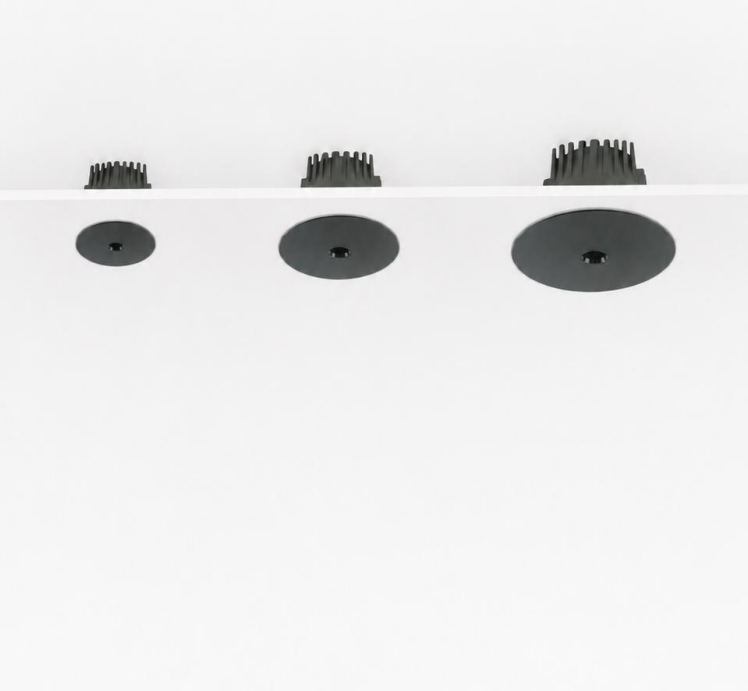

Small Aperture – Recessed

Lighting that responds. Design that adapts.

From quiet galleries to dynamic retail, Aria brings clarity and control to vertical lighting. Every detail—from optic precision to modular forms—is designed to deliver a uniform wash that adapts to changing needs.

With options for tilt, rotation, and smart control, Aria is more than a fixture—it's a flexible tool for shaping mood, focus, and flow.

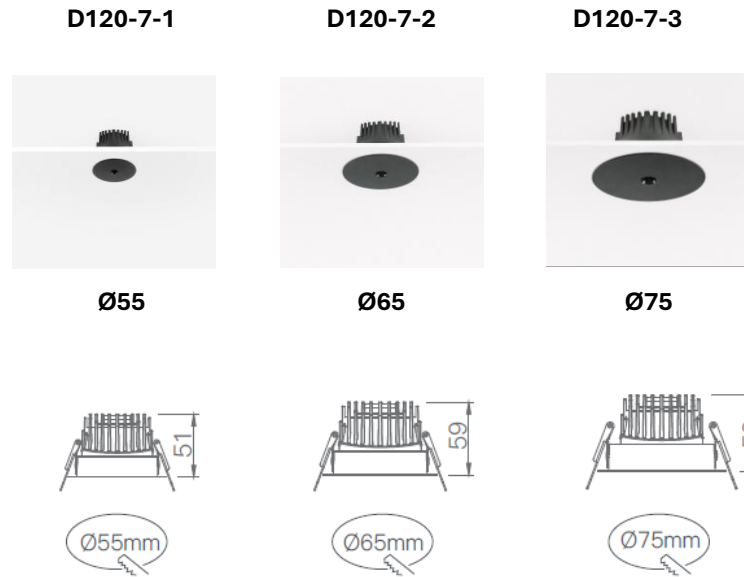

Model	Power	lm	CCT	CRI	SDCM	Beam	Driver	Ctrl
D120-7-1	5W	210 lm	2700K	90	≤3	24° / 36°	ON/OFF	Bluetooth
D120-7-2	8W	410 lm	3000K	92	≤3	24° / 36°	0-10V	DALI
D120-7-3	10W	440 lm	4000K	95	≤3	24° / 36°	Triac	
			Tunable White	98				

Remark	Remark
SDCM ≤3	R9
CRI-98	R9 = 60, @CRI90
	R9 = 75, @CRI95
	R15
	R15 = 85, @CRI90
	R15 = 90, @CRI95



Small Aperture – Surface Mount

Design that adapts.

From quiet galleries to dynamic retail, Aria brings clarity and control to vertical lighting. Every detail—from optic precision to modular forms—is designed to deliver a uniform wash that adapts to changing needs.

With options for tilt, rotation, and smart control, Aria is more than a fixture—it's a flexible tool for shaping mood, focus, and flow.

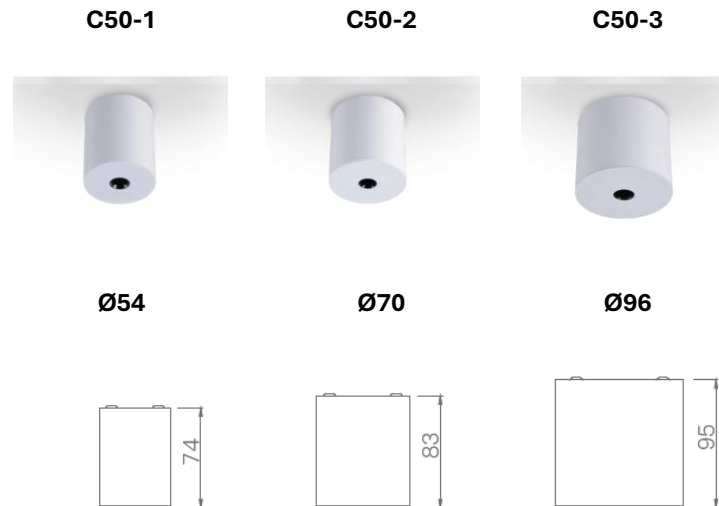

Model	Power	lm	CCT	CRI	SDCM	Beam	Driver	Ctrl
C50-1	5W	200 lm	2700K	90	≤3	24° / 36°	ON/OFF	Bluetooth
C50-2	9W	410 lm	3000K	92	≤3	24° / 36°	0-10V	DALI
C50-3	12W	720 lm	4000K	95	≤3	24° / 36°	Triac	
			Tunable White	98				

Remark	Remark
SDCM ≤3	R9 = 60, @CRI90
	R9 = 75, @CRI95
CRI-98	R15 = 85, @CRI90
	R15 = 90, @CRI95

For further information or technical details
Please don't hesitate to contact us.

<http://www.acofusion.com>

info@acofusion.com